

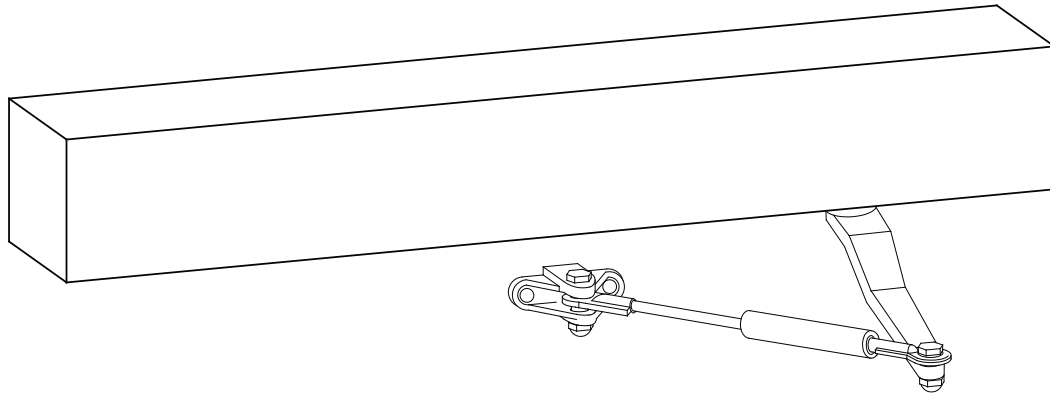

104850 March 28, 2011

Detex Corporation, 302 Detex Drive, New Braunfels, Texas 78130-3045
(830)-629-2900 / 1-800-729-3839 / Fax (830)-620-6711
E-MAIL: detex @ detex.com INTERNET: www.detex.com

DETEX Low Energy Automatic Door Operator AO19-1 Single Door - Push



CAUTION

Read this notice before installing or servicing

The Detex Low Energy Automatic Door Operator must be installed to comply with the latest revision of ANSI /BHMA A156.19 (American National Standard for Power Assist and Low Energy Power Operated Doors) and upon completion of installation, the owner should have an inspection performed by an AAADM certified inspector. In special applications where safety sensors are used on low energy doors, the sensors and the related adjustments should comply with the criteria set forth in ANSI/BHMA A156.10 (American National Standard for Power Operated Pedestrian Doors). Failure to conform to these requirements may cause operating failures which can result in serious injury or property damage.

It is the owner's responsibility to assure the reliable and safe operation of this device; routine service and inspection should be performed at least annually by an AAADM certified inspector. More frequent service may be required when the operating environment or other conditions dictate or if required by the local authority having jurisdiction. Proper operation should be checked everyday by the owner. Detex Corporation accepts no liability for property damage, warranty claims or personal injury, if this Detex product is not properly installed for compliance to these requirements by a qualified automatic door operator installer and also properly maintained and inspected by the owner to operate as required by ANSI/BHMA A156.19 (or ANSI/BHMA A156.10 where required).

Installer's Copy

Tools Required

1 - Knife	1 - 3/16" Drill bit	1 - Wire Stripper/Crimper
1 - Level	1 - 1/2 " Drill bit	1 - Hacksaw
1 - Tape Measure	1 - 3/8" Drill Motor	2 - 18" Bar Clamps
1 - # 2 Phillips	1 - 3/8" Drill bit	1 - Set Allen Wrenches
1 - # 3 Phillips Bit	1 - Box 3/16" x 1 1/4" Tapcons	1 - Safety Glasses
	1/4-20 or #14 Flat Head Screws	1 - Thin Brush

General Conditions

The Detex Low Energy Automatic Door Operator is designed for Residential, Commercial and Industrial use. If is to be retrofitted on to an existing door and frame, it is important that the door is in good condition and swings freely, without restriction. It is also important that the header is sturdy and the operator must be fastened securely using the appropriate fasteners.

WARNING: To reduce the risk of injuries to persons – use this operator only with a 250 lb. door(s) max.

All electrical wiring must comply with the National Electrical Code.

Not compatible with GFI (Ground Fault Interrupt) Breaker.

The Detex Low Energy Automatic Door Operator must be installed to comply with ANSI/BHMA A156.19 standards. It is not a solution to wind or stack air conditions. If these conditions exist, please call factory for further information and possible solutions.

Beware that the door should: 1) open to at least 32" of clear opening; 2) have 5' x 5' of flat floor on both sides; 3) be protected at bottom rail, 7 1/2" up; 4) threshold must meet ADA Guidelines; and 5) a commercial or residential swinging pedestrian door shall not close with a force greater than 15 lb. at the latch side of the closing stile and shall not close through the final 10 degrees in less than 1.5 seconds.

Receiving Inspection

Verify that the device ordered is the correct model for the door application. Inspect package for possible shipping damages. Carefully cut tape and open cardboard shipping box. Packed into this box you will typically find arm assembly, door decal(s), complete low energy operator and instruction documents. Remove items and place them carefully aside so they will not be damaged or lost. Using a #2 Phillips, remove the cover screws and lift cover. Remove packing and inspect all items before continuing.

Contact Factory on damages and missing equipment

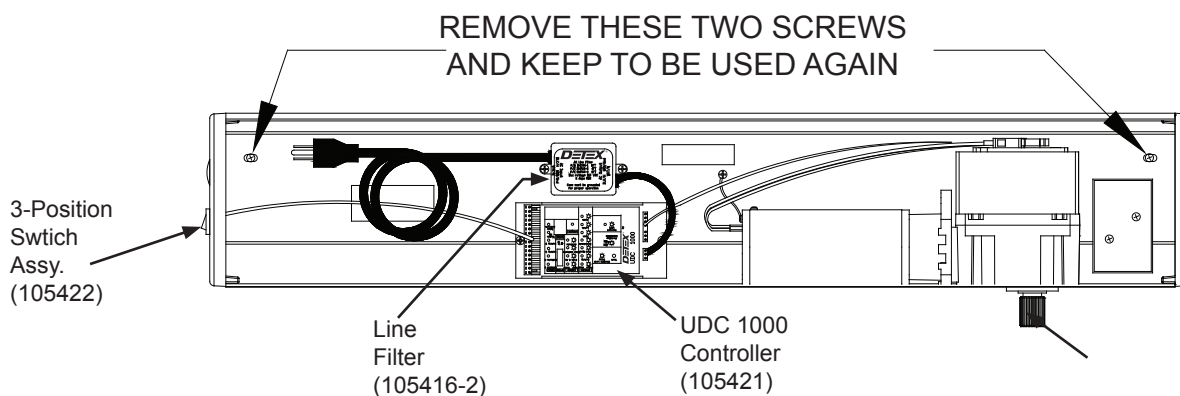

Installation Preparation

The hanger bracket assembly is unique to the Detex Low Energy Automatic Door Operator. It allows the installation to be performed by one person, quickly and efficiently.

Locate Phillips screws inside at the top corners. Remove these (screws will be used again) and separate the enclosure from the hanger plate.

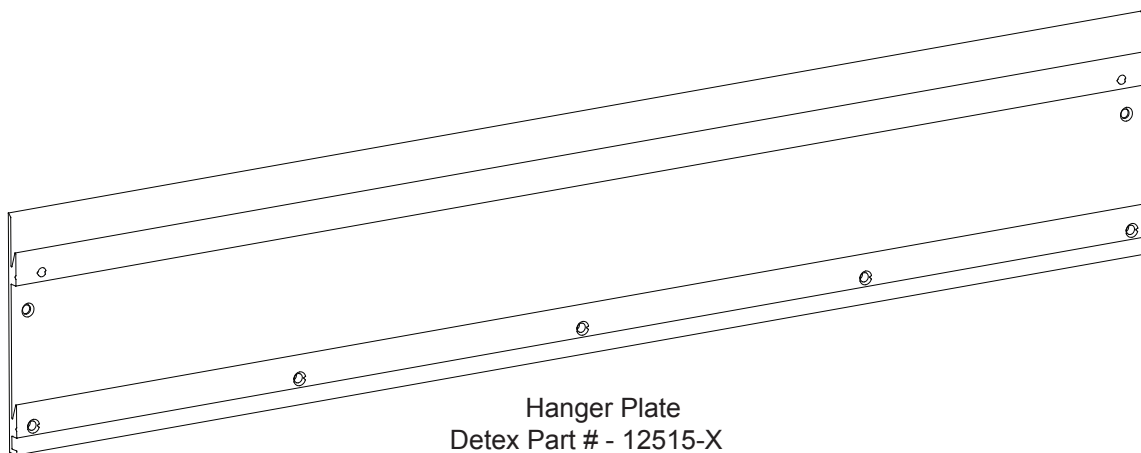

Installation

Hanger Plate Location for Single or Pair Push Units

The hanger plate should be located 5/8" from the outside edge of the hinge jamb, (typical 1 3/4" frame face) level and flush with the bottom of the header of the door frame. Bar clamp the hanger plate. Using hanger plate, mark and drill holes into header frame, solid wall or wall stud. Fasten using appropriate type and size screws (Detex recommends using flat head type).

Note: Drilling debris accumulated in hanger groove tracks can prevent the operator from seating uniformly when mounting. Remove debris with thin brush. Masking tape can also be used to prevent debris from collecting in groove.

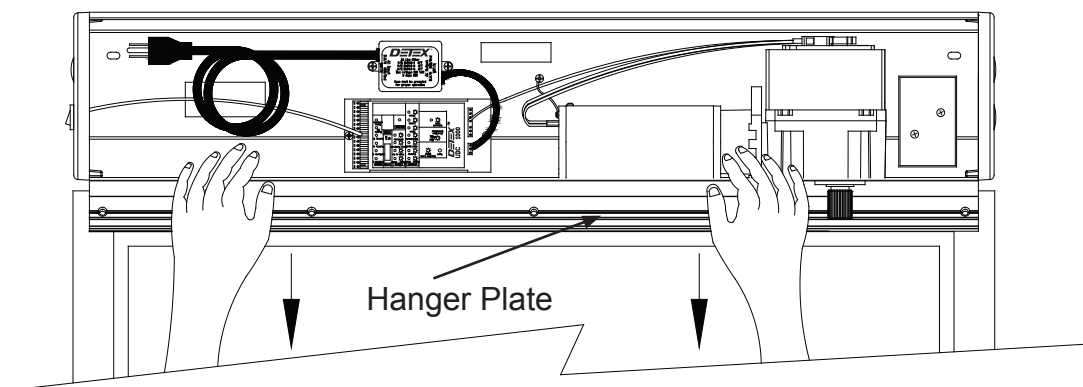
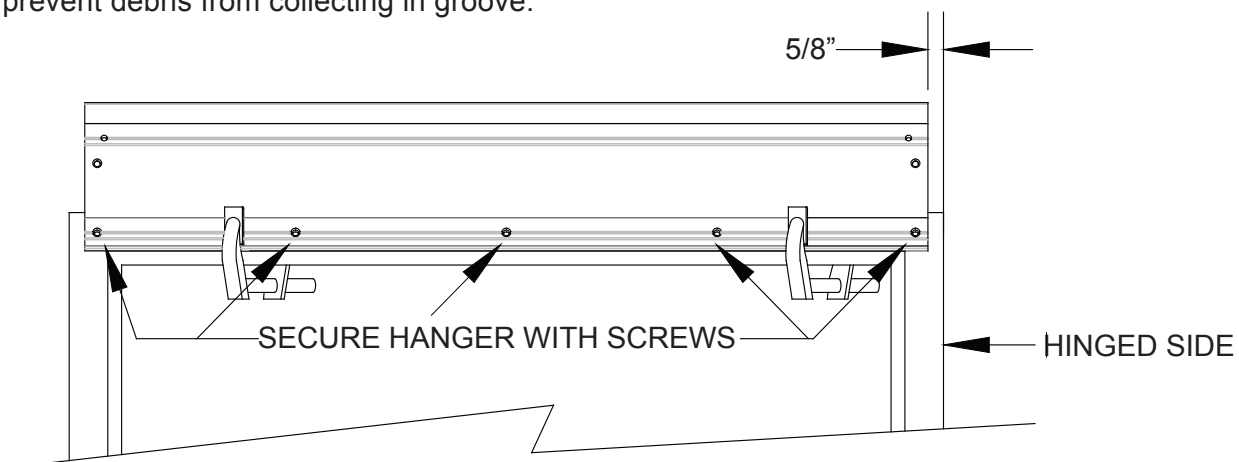

Lift the operator and lower onto the webs of the hanger plate bracket. Be sure both top and bottom are engaged.

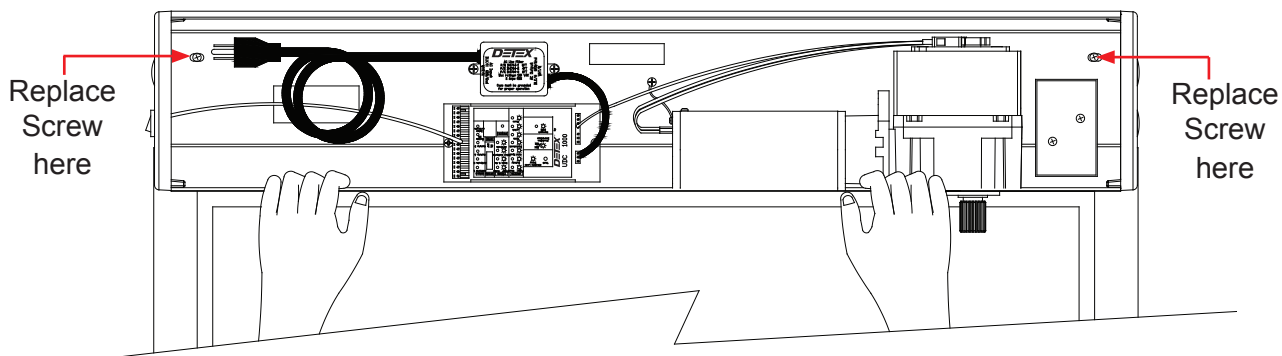

Once they are seated, pull down until unit is completely flush and screws can be replaced in top corners.

120 vAC RMS Connections

Have a licensed electrician bring 120 vAC RMS to the Detex Low Energy Automatic Door Operator in accordance with all local and state electrical codes. Be sure the 120 vAC RMS power supply is turned off before proceeding. The 120 vAC RMS power line can be run thru the knockout hole at the end of the operator case and into the outlet box provided. You should inspect all wiring at this time before turning on power and connecting electrical cord to outlet connector.

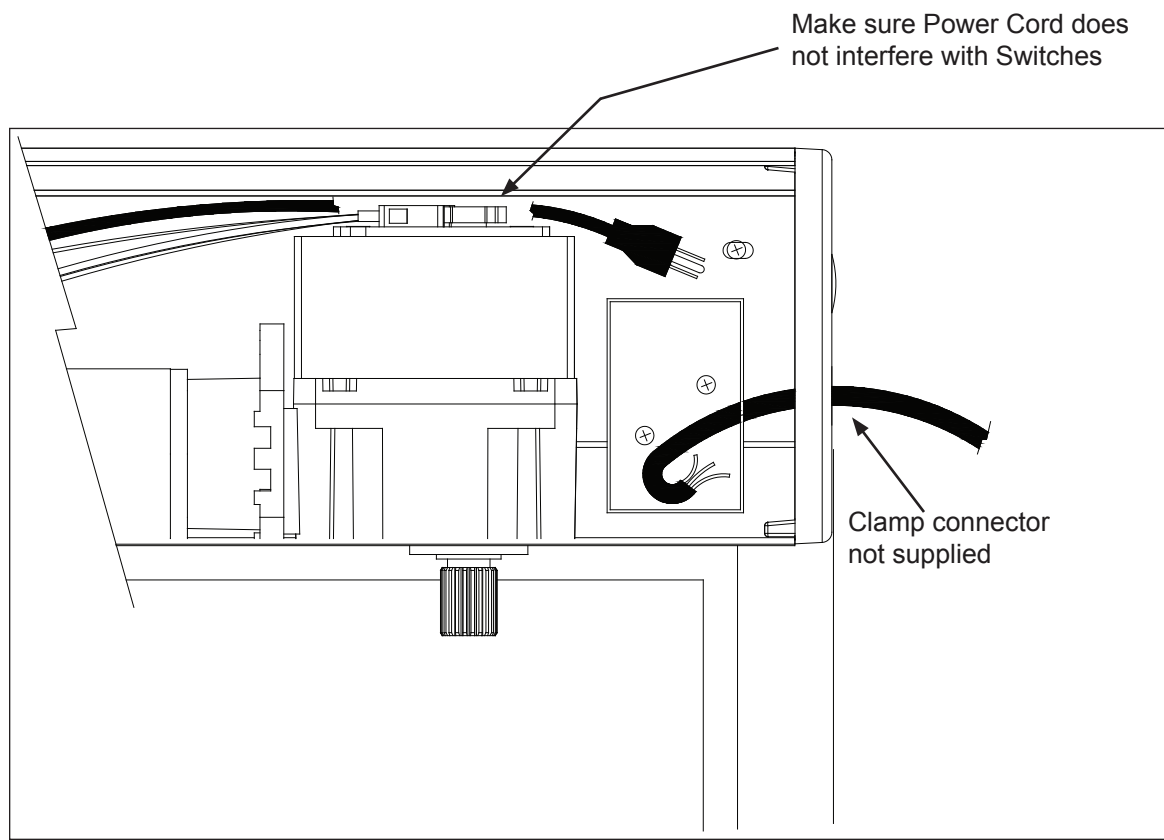

120 vAC RMS to Controller Module connection

**Connection from 120 vAC RMS source
Performed by licensed electrician.**

Push Arm Installation

Review the Installation Guide for Detex Low Energy Automatic Door Operator Control Module, P/N 104827 before proceeding. We have preset controls to approximate settings. Turn the 3-way toggle switch, located at end of enclosure, to "HOLD" position. The operator will activate and the motor output shaft will rotate 240° (degrees). While in the full open position, attach the arm onto the shaft so that it is pointed at a 70°-80° (degrees) angle through the door opening. Tighten the screw on the arm to secure it to the shaft.

Be sure the motor gear shaft is full open position by forcing arm to rotate past it's stop position. If you can rotate gear shaft beyond it's position, increase the "BACK-CHECK" and HOLD speeds. Switch toggle to OFF then back to "HOLD". Realign arm in proper position. Tighten the screw on the arm to secure it to the shaft and apply the safety washer to the bottom of shaft.

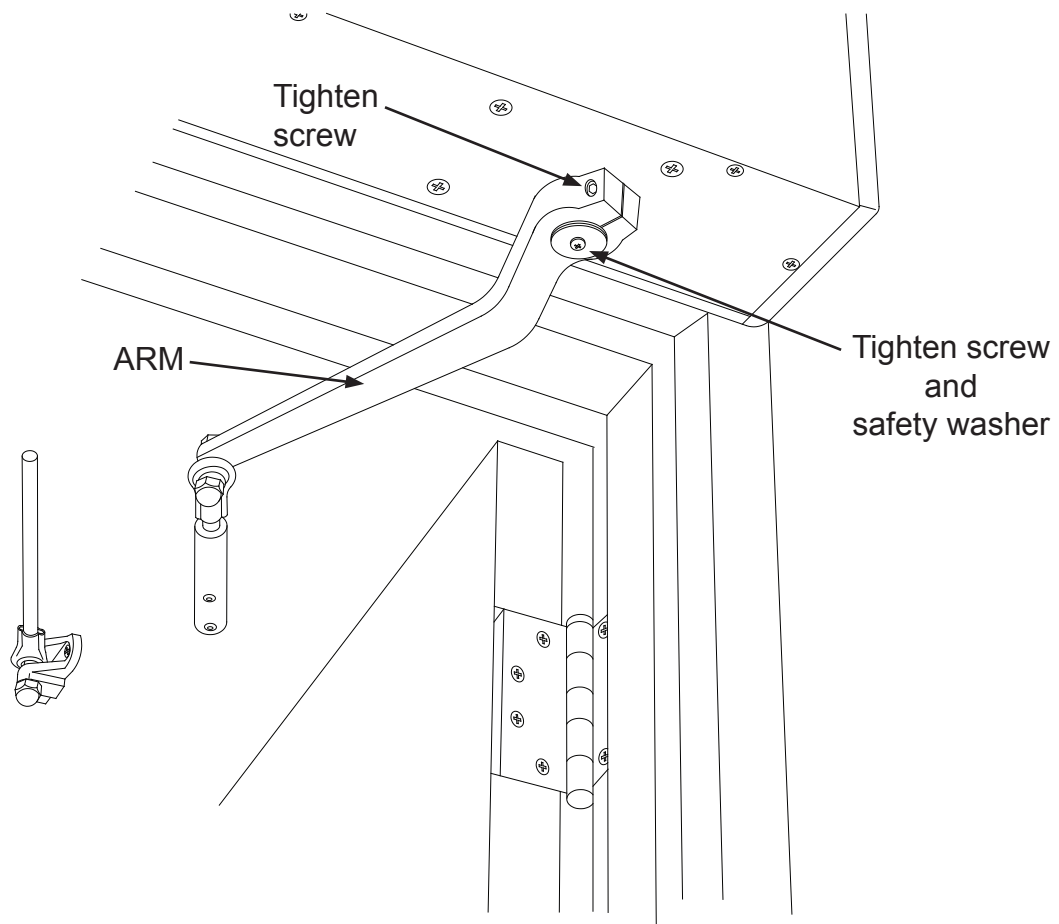

Arm placement in full open position

Door Foot Location - for Push Units

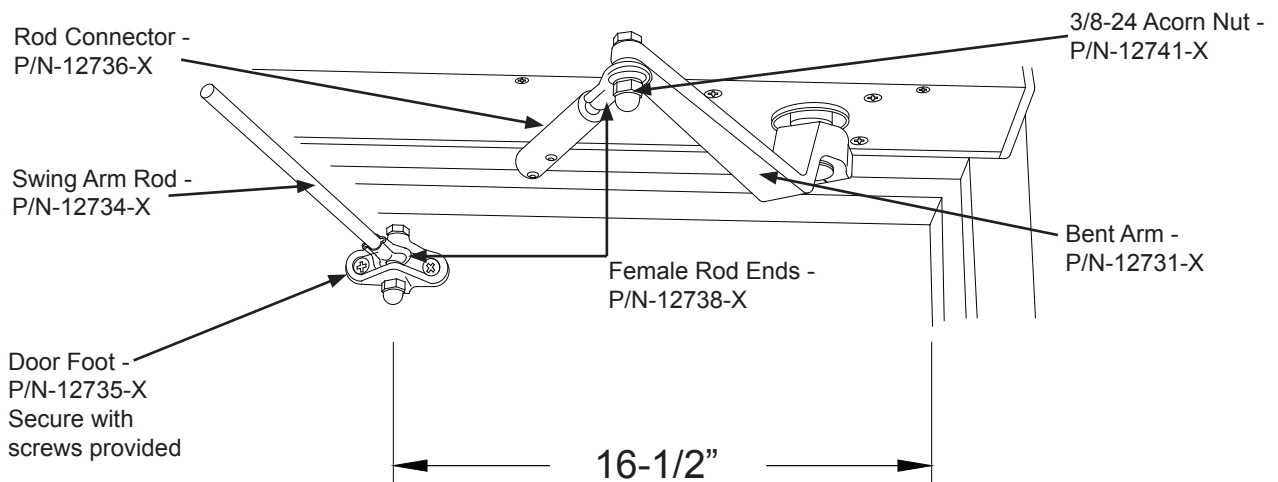

The center of the door foot should be located 16 1/2" from the hinge side of the door panel and should be level when the rod is inserted in the sleeve attached to the arm.

Mark the door for the door foot holes and secure the foot to the door with the supplied screws.

Turn the 3-way toggle switch to the "HOLD" position.

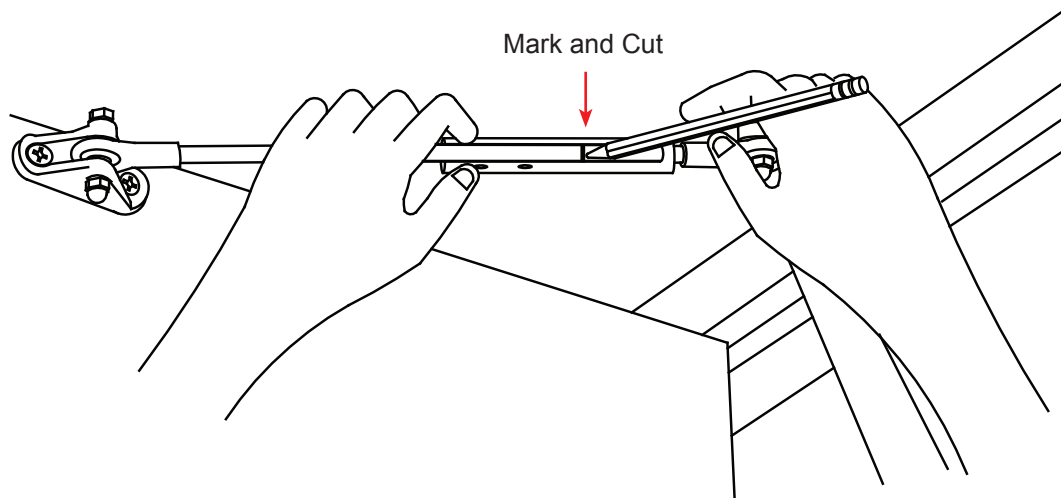

With the door at full open, hold the steel rod next to the rod connector at the end of the arm, mark and cut the rod so it will fit into the rod connector. The rod length should allow the rod to be secured with both set screws and allow for adjustment of the door opening. Insert the rod into the connector with the door in full open position and adjust until the desired opening is achieved. Tighten the set screws to secure the rod.

Low Voltage Activation Connections

You must disconnect all voltage sources before attempting to install an accessory.

Along with your Detex Low Energy Automatic Door Operator, you received an Installation Guide for Detex Low Energy Operator Control Module, P/N 104827. This document will help with the proper set up, switch options and wiring schematics.

The ON/OFF/HOLD 3-way toggle switch has been pre-wired into the Control Module and is located at one end of the enclosure.

Before any adjustments can be made the following check must be performed. First the arm must be properly connected to the door leaf. The power must be connected and the switch in the ON position. The door leaf must be fully closed. Examine the Door Control. The control board must have three lights illuminated (LATCH, POWER, and MODULE ON). If the CLOSE light is on, review the arm assembly location by manually opening door leaf until it is stopped by internal stop. If the door arm rotates well beyond 80 degrees refer back to arm installation directions. If arm stops at approximately 80 degrees, allow the leaf to close.

The LATCH-CHECK AND BACK-CHECK are controlled via the cam on top of the gearbox. Access is thru the top of the operator case directly above the gearbox. Using a 1/8th inch Allen wrench, gently loosen the screw that holds the cam in place. Rotate cam in the closing rotation direction until the CLOSE light goes out and the LATCH light comes on. Holding the cam in place gently retighten the holding screw.

DO NOT OVER TIGHTEN AS THAT WILL DAMAGE THE CAM.

Test the LATCH-CHECK position by manually opening the door leaf until you see LATCH-CHECK light go out and the CLOSE light comes on. This should be approximately 4 inches from Jamb. Fine tune adjustment as necessary.

If the lights fail to work call for factory assistance.

THE DETEX, LOW ENERGY AUTOMATIC DOOR OPERATOR, IS TO BE USED WITH APPROVED SWITCHES.

Contact factory for information on Sensor connections.

Typically you will use a wall mounted, hard wired push button for activation. You must provide wire from the push button switch to the Control Module inputs. Knockouts are available on the enclosure for wire runs. The connections are terminated on **terminals #1 and #2 of the Control Module**. Refer to the diagram included with the Control Module.

BE SURE ALL WIRING MEETS ALL STATE AND LOCAL CODES.

Button Location

Locate the buttons securely to a wall or post. Be sure the button is not blocked by opened door or cause the user to be in the path of the door leaf when opening. Check local codes for variations in location requirements.

Another popular type of button has battery-operated transmitters. They work with a receiver mounted in operator case. The receiver may be connected to the Control Module for a source of power. Connect power wires to #12 and #13 for A.C., or #1 and #11 for D.C. Connect the "COM" and "N.O." outputs from the receiver to terminals #1 and #2 of the Control Module.

Each transmitter setting must be programmed to same setting of the receiver to operate correctly.

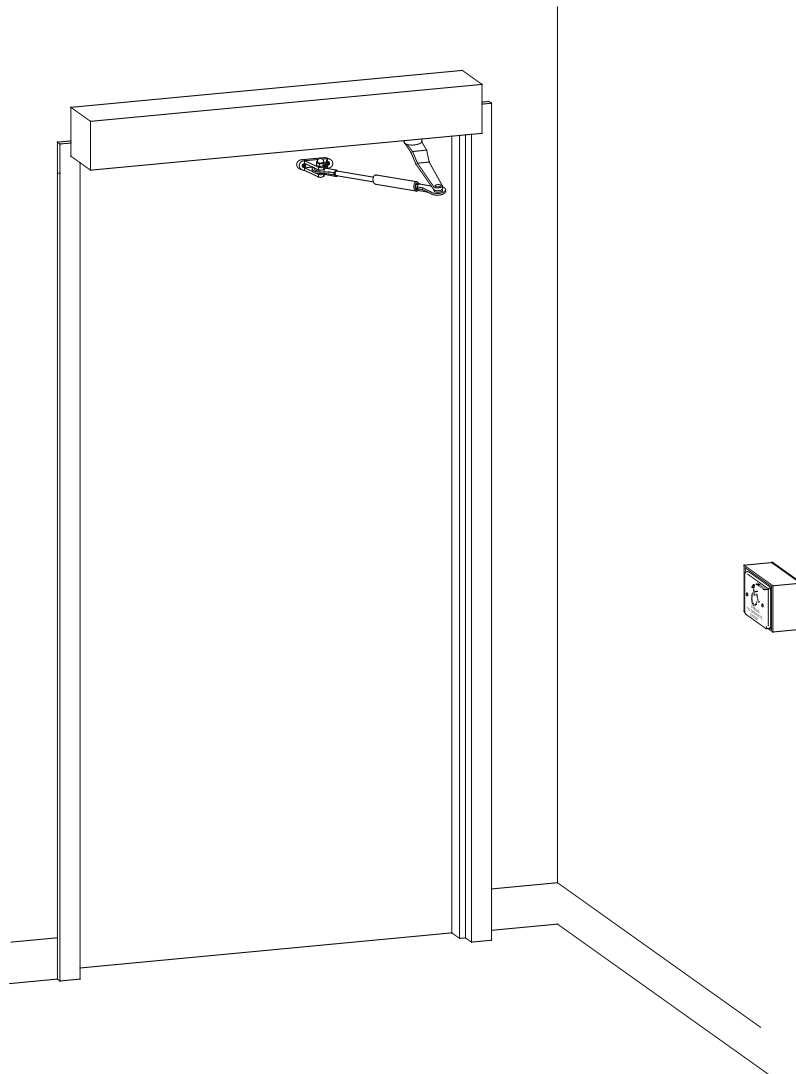

Per ANSI/BHMA A156.19, switch is to be installed within view of door at a maximum distance of 144" (3658 mm) from the center of the door and mounted a minimum of 36" (914 mm) and a maximum 48" (1219 mm) from the finished floor.

Decal Application

You've been provided with a double-side decal that meets ANSI/BHMA A156.19, as follows:
A door shall be marked with a decal, visible from the swing side, with the words

“AUTOMATIC CAUTION DOOR”

The sign shall be mounted on door at a height 58 in. +/- 5 in. from the floor to center line of the sign.
The sign shall be a minimum of 6 in. in diameter with black lettering on a yellow background.



Decal
(104787)

Final Inspection

Before leaving site, test all activation devices and time your door. To reduce call-backs, instruct owner on the legal operation of door, how to turn on and off, function and warranty considerations.

This operator must be installed/serviced by a qualified person. The service technician must be familiar with the latest ANSI/BHMA A156.10/19 standards.

**Call factory for technical support
800-729-3839**