

F2000R Series

FIRE RATED EXIT DEVICE

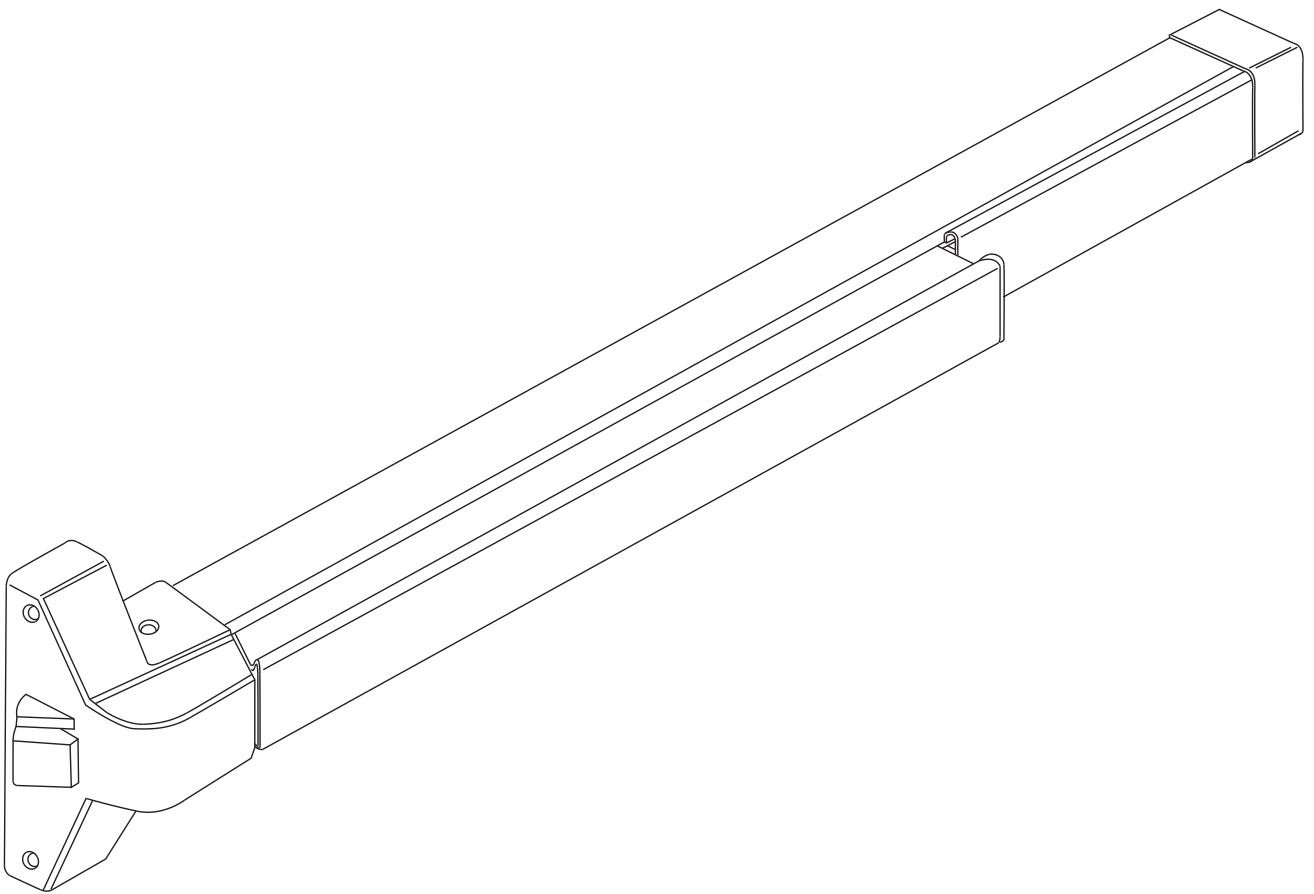

INSTALLATION INSTRUCTIONS

1 PARTS NAME

IF YOUR DOOR IS NARROWER THAN 36" , REMOVE END COVER AND CUT SECTION "A" TO A DESIRED LENGTH.

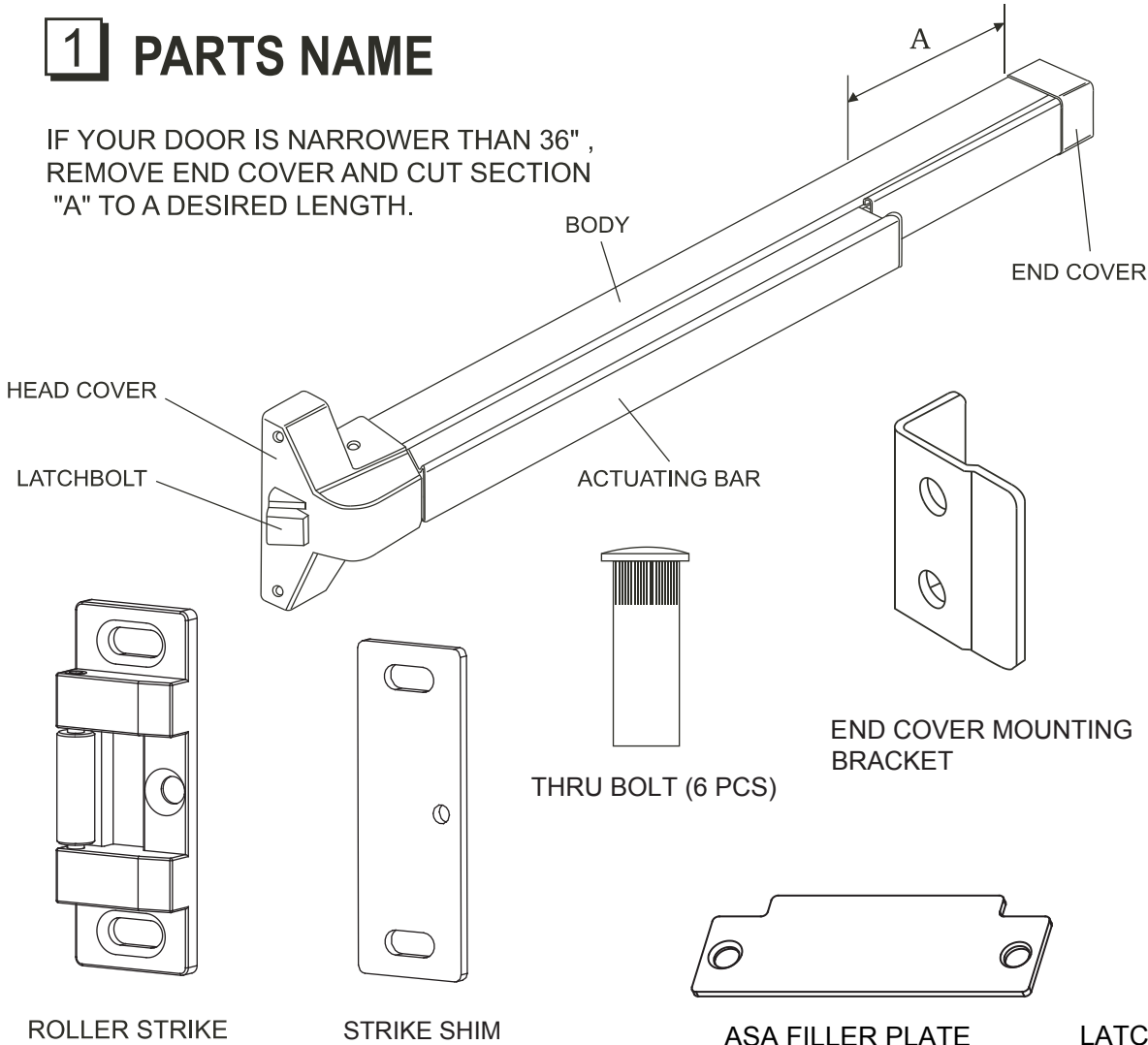

1/4"x1 1/2" (9 PCS)
SELF TAPPING
MACHINE SCREWS

1/4"-20P x 3/4" (3 PCS)
FLAT HEAD
MACHINE SCREWS

1/4"-20P x 3/4" (6 PCS)
ROUND HEAD
MACHINE SCREWS

1/4"x 1 1/4" (3 PCS)
FLAT HEAD
WOOD SCREWS

1/4"x 1 1/4" (6 PCS)
ROUND HEAD
WOOD SCREWS

2 OPTIONAL PARTS

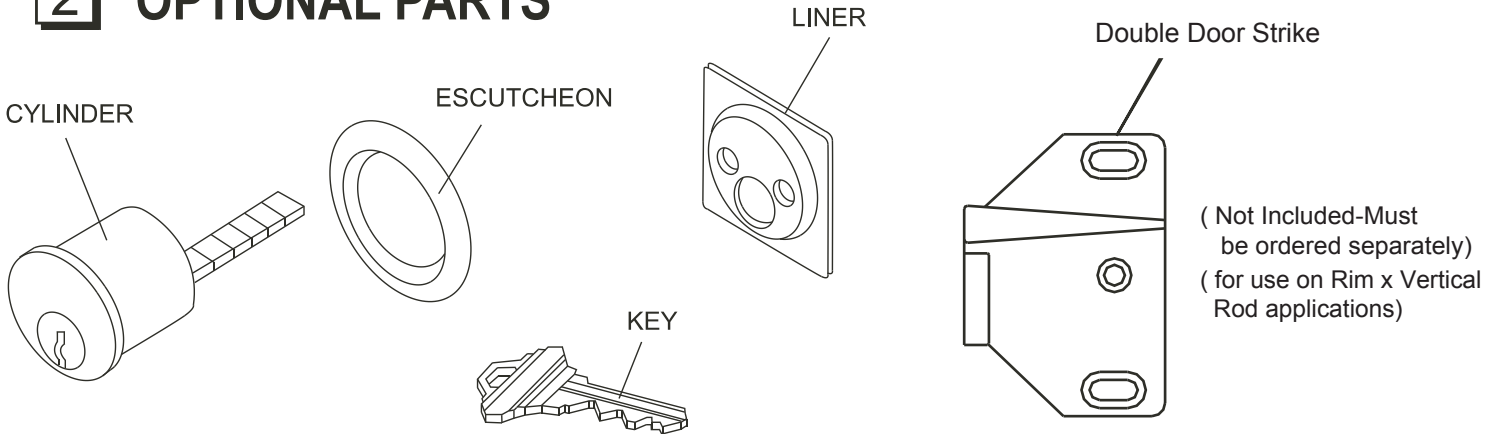

3 TYPE OF INSTALLATION

A. SINGLE DOOR

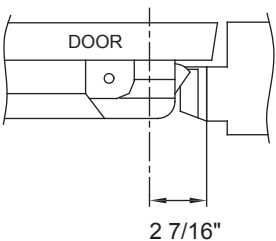

B. DOUBLE DOOR WITH MULLION

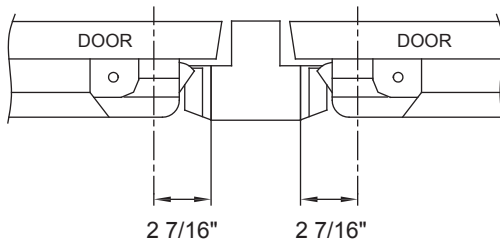

C. DOUBLE DOOR WITHOUT MULLION

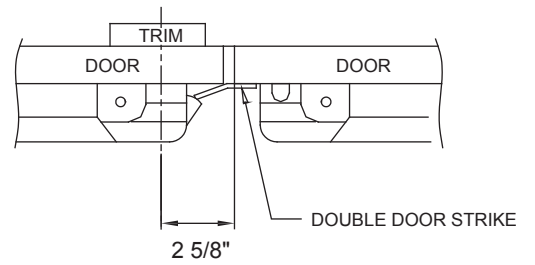

4 DRILL HOLES

1. USE TEMPLATE ENCLOSED TO MARK DOOR FACE AND DRILL HOLES IN ACCORDANCE WITH THE DIAMETERS SUGGESTED.
2. "B" LENGTH SHOULD BE MEASURED FROM THE CENTER OF CYLINDER HOLE TO THE END OF THE BODY.

Drill $9/32$ " holes inside and $3/8$ " holes outside for the (6) thru bolts and drill & tap for (3) $1/4$ "x20 machine screws for the Roller Strike.

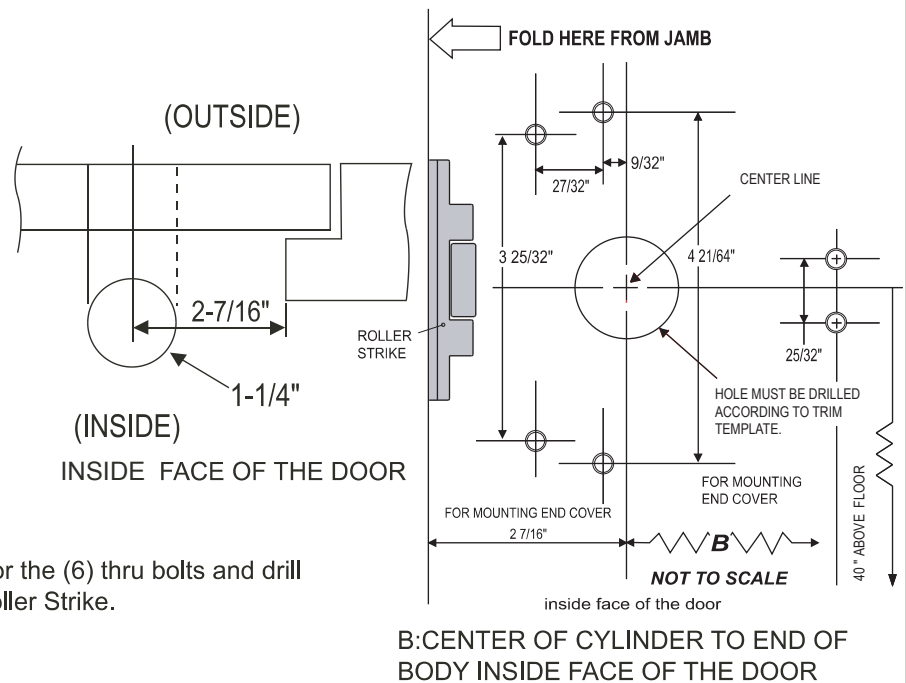

B: CENTER OF CYLINDER TO END OF BODY INSIDE FACE OF THE DOOR

5 INSTALL CYLINDER (IF REQUIRED)

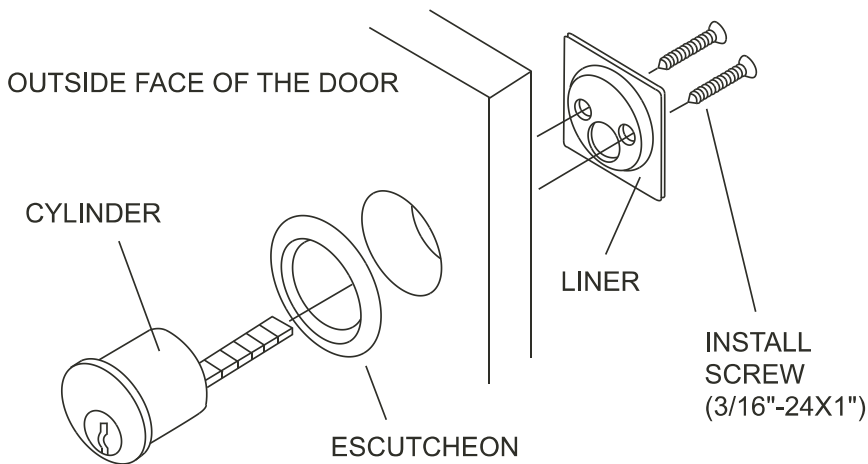

1. INSERT THE CYLINDER INTO THE HOLE ON THE DOOR
2. KEEP THE TAILPIECE HORIZONTAL
3. TIGHTEN THE SCREWS

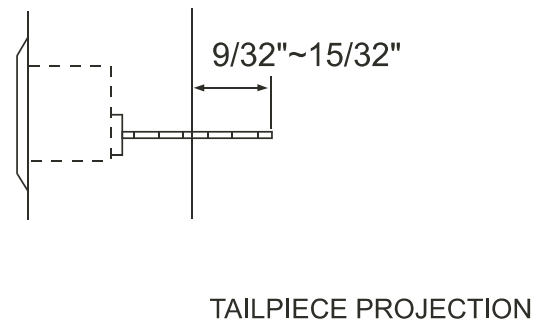

6 INSTALL BODY

1. REMOVE THE HEAD COVER AND END COVER.
2. ALIGN THE SCREW HOLES ON THE BODY WITH THE HOLES ON THE DOOR.
3. INSERT SCREW BOLT (6PCS) $3/8$ " FROM OUTSIDE OF THE DOOR THEN TIGHTEN THE $1/4$ " ROUND HEAD SCREW (6PCS) FROM INSIDE OF THE DOOR ON THE BODY AND THE MOUNTING PLATE OF END COVER.

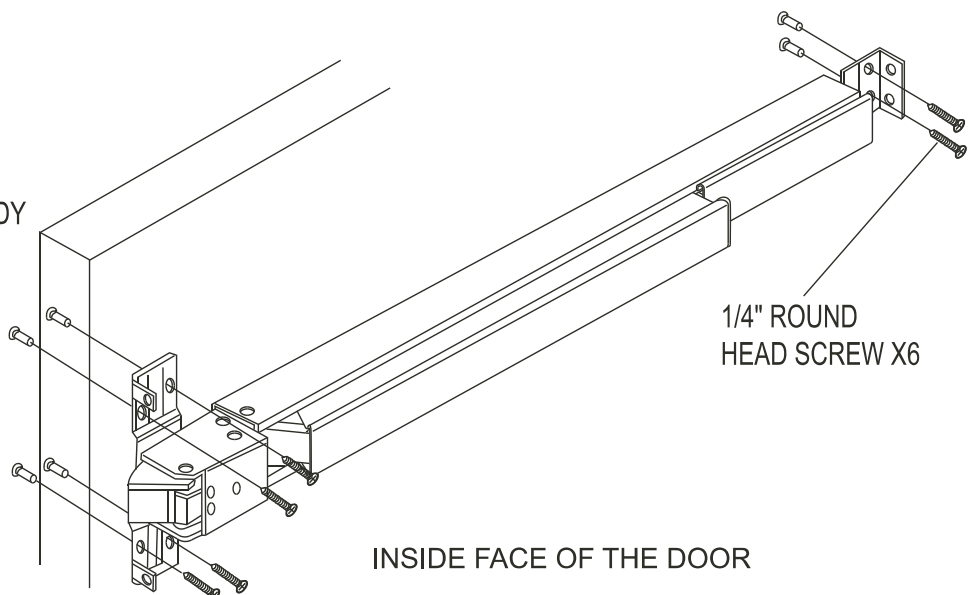

INSIDE FACE OF THE DOOR

7 INSTALL HEAD COVER AND END COVER

1. PUT ON THE HEAD COVER AND END COVER
2. TIGHTEN THE SCREWS SECURELY ON THE HEAD COVER AND THE END COVER.

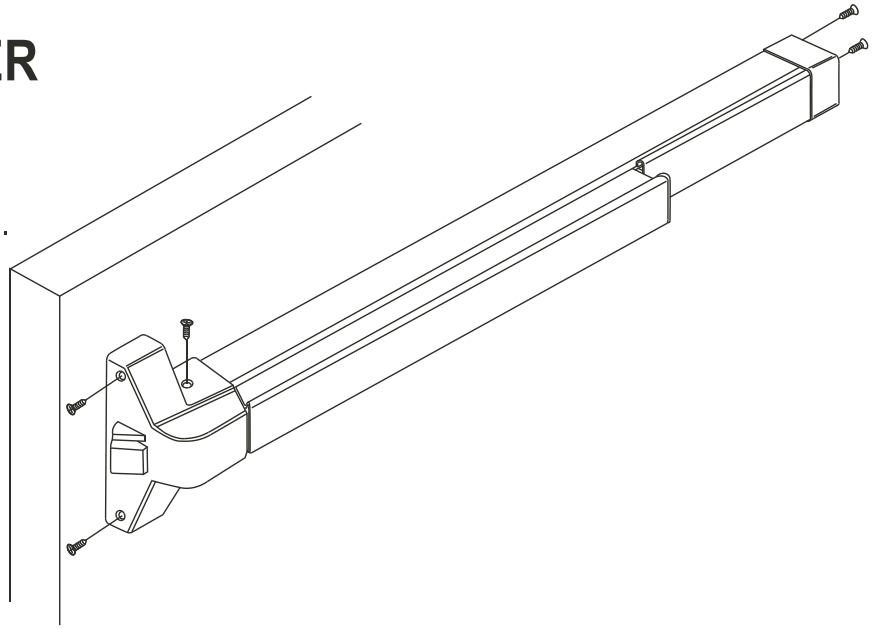

8 INSTALL ROLLER STRIKE

1. WITH THE DOOR IN THE CLOSED POSITION MARK THE CENTERLINE OF LATCHBOLT ON DOOR JAMB.
2. PLACE ROLLER STRIKE ON DOOR JAMB. ALIGN CENTER OF ROLLER STRIKE WITH THE LATCHBOLT CENTERLINE MARK ON THE JAMB. THEN ALIGN THE OUTSIDE EDGE OF THE ROLLER STRIKE WITH THE OUTSIDE EDGE OF THE DOOR JAMB.

3. MARK THE CENTER OF THE 2 ADJUSTABLE SLOTTED HOLES AND DRILL $7/32$ " PILOT HOLES. TAP PILOT HOLES WITH $1/4$ "-20 THREADS AND INSTALL MACHINE SCREWS. OR INSTALL SELF TAPPING MACHINE SCREWS OR WOOD SCREWS IN PILOT HOLES. CLOSE DOOR TO CHECK IF LATCHBOLT EXTENDS PROPERLY, ADJUST ROLLER STRIKE IF NECESSARY.

4. WITH ROLLER STRIKE IN FINAL POSITION, DRILL A $7/32$ " PILOT HOLE FOR THE CENTER MOUNTING HOLE. TAP PILOT HOLE WITH $1/4$ "-20 THREADS AND INSTALL MACHINE SCREW. OR INSTALL SELF TAPPING MACHINE SCREW OR WOOD SCREW IN PILOT HOLE.

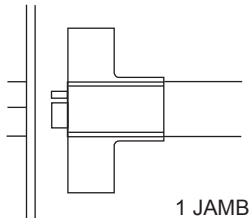

1 JAMB

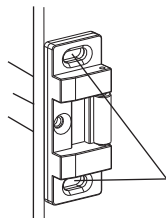

2. ADJUSTABLE SLOT

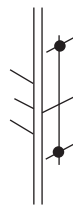

3. DRILL $7/32$ " HOLE, TAP $1/4$ "-20P THREAD

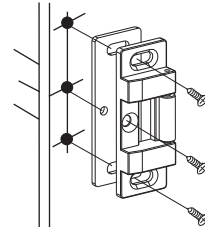

4. $1/4$ "-20P FLAT HEAD SCREW

NOTE : INSTALL STRIKE SHIM UNLESS THE EXIT DEVICE HEAD COVER RUBS THE ROLLER STRIKE. THEN REMOVE THE STRIKE SHIM TO GAIN ADDITIONAL CLEARANCE.

9 OPERATION TEST

PRESS DOWN THE ACTUATING BAR. OPEN AND CLOSE DOOR A FEW TIMES AFTER INSTALLATION COMPLETED

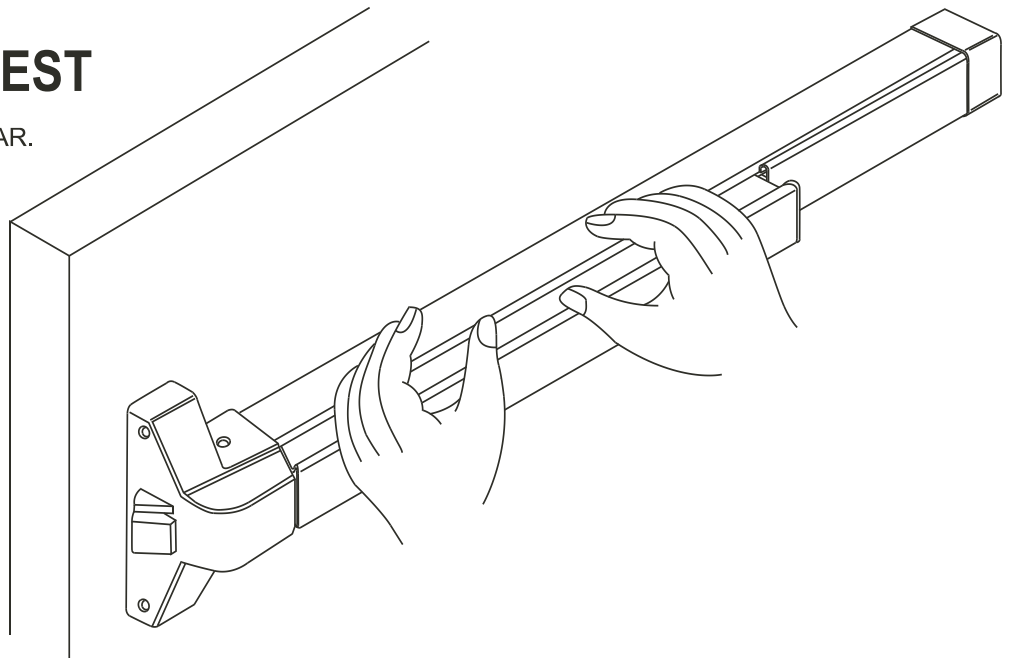

TEMPLATE FOR INSTALLING PANIC EXIT DEVICE

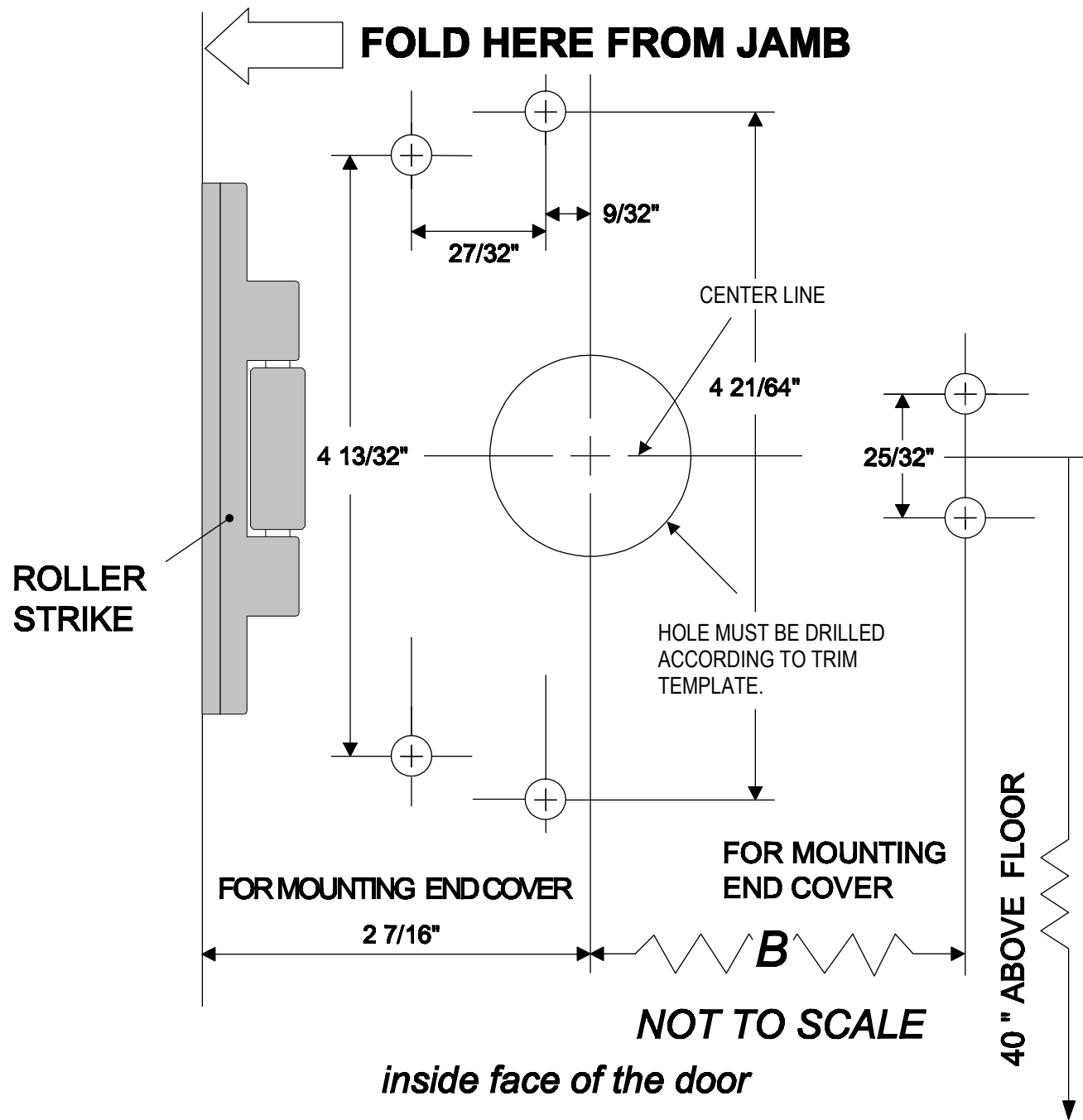
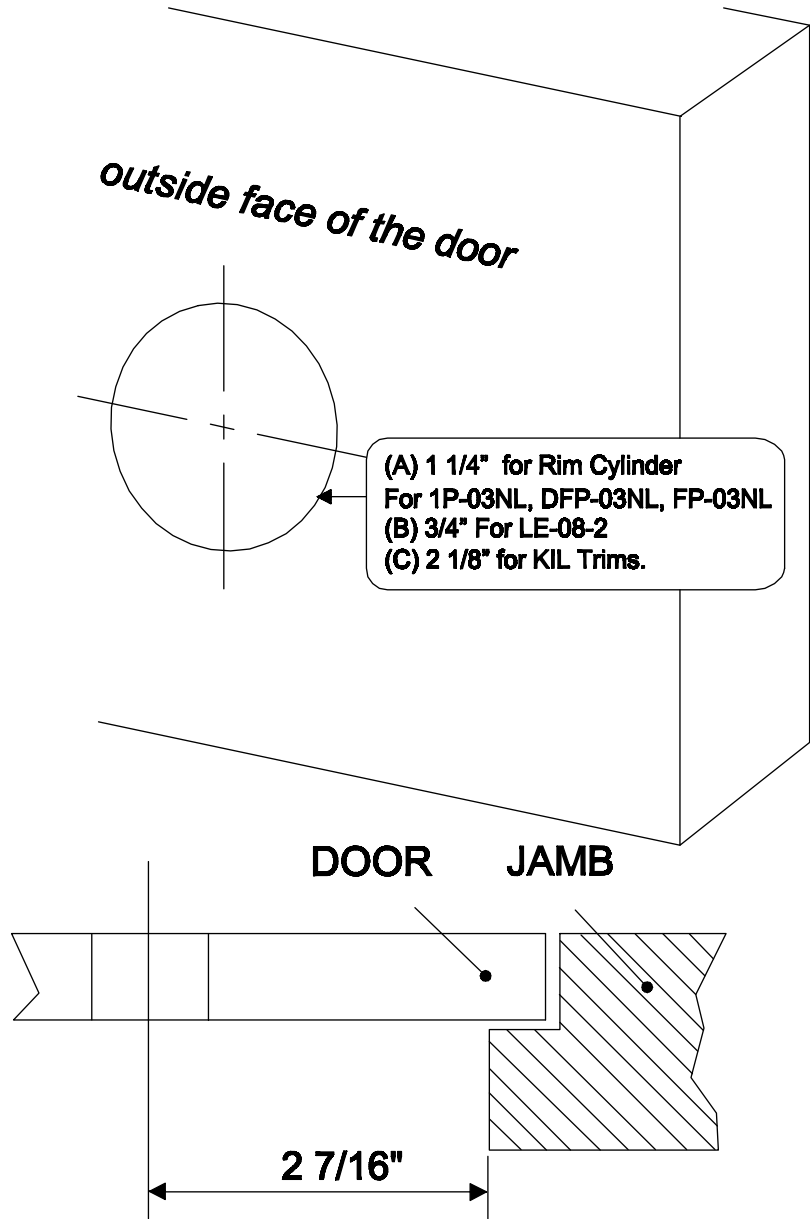

- (A) For 2000R Series (UL Listed)-Drill & tap for (6) 1/4"x20 machine screws for Exit Device and Drill & tap for (3) 1/4"x20 machine screws for Roller Strike
OPTIONAL for 2000R (UL Listed)
Drill (6) 7/32" Pilot Holes for Self Tapping machine screws or wood screws for Exit Device and
Drill (3) 7/32" Pilot Holes for Self Tapping machine screws or wood screws for Roller Strike
- (B) For F2000R (Fire Rated)-Drill 9/32" holes inside and 3/8" holes outside for the (6) thru bolts and drill & tap for (3) 1/4"x20 machine screws for Roller Strike.