

USING THE LATCH SPACER SHIMS

The latch spacer shims are used to make adjustments to minimize the space between the door's inside face and the door stop or reduce door play. For cylindrical locks aligning to the vertical center of the strike mount the shims as shown below.

Mount the shims with the steps positioned aligned with the top of the latch like this.

This position will ensure that the cylindrical lock's auxiliary trigger will function properly.

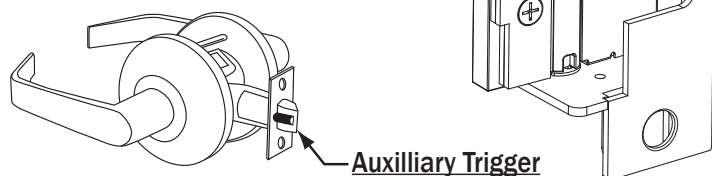

TROUBLESHOOTING THE COMPLETED INSTALLATION:

DO NOT APPLY AN OVER VOLTAGE OF MORE THAN 10% OVER THE RATED OPERATING VOLTAGE OF THE STRIKE OR THE SOLENOID WILL BE DAMAGED

SYMPTOM: Electric release is not actuating:

1. Verify proper voltage is present AT THE STRIKE. If voltage is present, the strike may have been affected during the installation, or dirt or debris may be preventing proper operation. Ensure that all moving parts are clean. **DO NOT LUBRICATE THE SOLENOID.**
2. If voltage IS NOT present:
 - Verify Circuit breaker is on
 - Verify voltage at the transformer/power supply output.
 - Verify that there are no additional, external switches or devices which may be interrupting your circuit.
 - Check for damaged wiring or bad wire splices.

USING THE LATCH SPACER SHIMS (CONTINUED...)

For locks not aligning to the vertical center of the strike, mount the shims as shown below. Most if not all mortise locks will work with the latch shims mounted this way.

Mount the shims with the steps positioned away from the top of the latch like this.

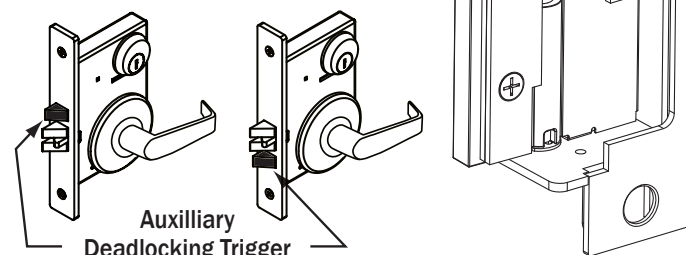

PREMIUM TRIM SKIRT FOR THE 4100

USING THE TRIM SKIRT

The skirt can be used to clean up the cut line of the frame face during installation. The Trim Skirt comes with 2 screws for fastening to the top and bottom of the 4100.

Available in 6 architectural finishes: US32D, US32, US3, US4, US10, US10B to match the finish of the electric strike and faceplates.

CCTS

If retrofitting for the electric strikes listed below, a separate Skirt may be used to cover the gap left in the frame. Note: Specify the finish of the CCTS so it matches the 4100 you have.

H.E.S.® 1006, Folger Adams® 712/732, Von Duprin® 6200 Series, or Trine EN Series Strikes

TRINE
ACCESS TECHNOLOGY

PHONE: (718) 829-2332 FAX: (718) 829-6405
1440 FERRIS PLACE
BRONX, NY 10461
email: customerservice@trineonline.com
website: www.trineonline.com

4100 ELECTRIC STRIKE

INSTALLATION INSTRUCTIONS

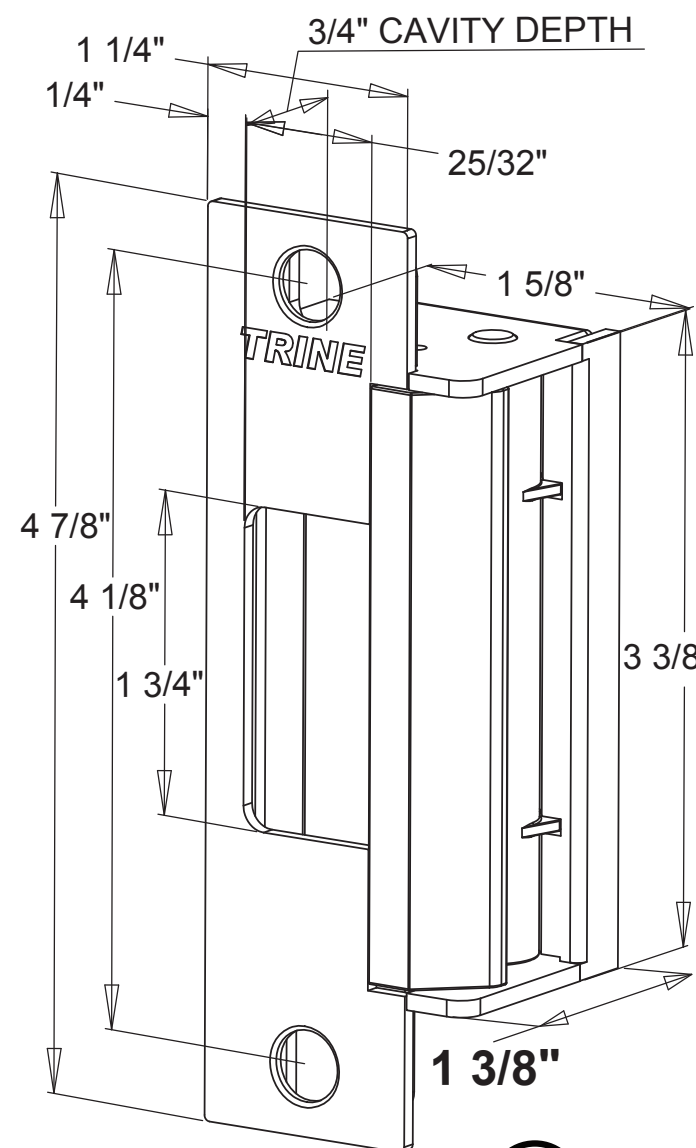

AXION
PREMIUM ELECTRIC STRIKES

TRINE 4100 THE ONE BOX SOLUTION FOR CYLINDRICAL AND MORTISE LOCKS

Congratulations on the purchase of this quality TRINE security product. This product has been designed to install easily, perform reliably, and provide years of trouble free security.

BEFORE PROCEEDING with your installation, please review the following list of features. If you have any questions after reading this document please call TRINE's TECHNICAL SUPPORT (718) 829-2332 EXT. 447, or visit the TRINE Web site at www.trineonline.com

The 4100 is WH recognized for:

- Class A, 3 Hour Single door / frame configuration
- UL10C, Fire Tests of Door Assemblies
- UBC 7-2, Uniform building Code
- CAN4 S104, Standard Method for Fire Tests of Door Assemblies
- NFPA 252 -
- Issue: 1999/01/01 Standard Methods of Fire Tests of Door Assemblies

NOTE: WH fire listing is void when using fail safe action.

UL LISTED - 1034 Burglary Resistant Locking (January 2013)
Mechanism for Indoor Use ONLY
ANSI/BHMA A156.5 - 1992 - 4-7/8" x 1-1/4" Fits
Cutout Specification A115.1 (with Slight Jamb Modification)
BHMA - Grade 1

EN4100 ELECTRICAL CHARACTERISTICS:

Voltage	Current Draw	Power Consumption	Resistance
12DC	.240 A	2.90 W	50 Ω
24DC	.114 A	2.74 W	210 Ω
12AC	.210 A	2.50 W	50 Ω
16AC	.281 A	4.48 W	50 Ω
24AC	.420 A	10.08 W	50 Ω

OPERATING TEMP RANGE: -20° C TO +40° C

DO NOT APPLY AN OVER VOLTAGE OF MORE THAN 10% OVER THE RATED OPERATING VOLTAGE OF THE STRIKE OR THE SOLENOID WILL BE DAMAGED

AVAILABLE FINISHES:

US32D (630) Satin Stainless	US10B (613) Dark Bronze
US32 (629) Bright Stainless	US10 (612) Satin Bronze
US3 (605) Bright Brass	US4 (606) Satin Brass

TRINE
ACCESS TECHNOLOGY
1440 Ferris Place | Bronx | New York | 10461

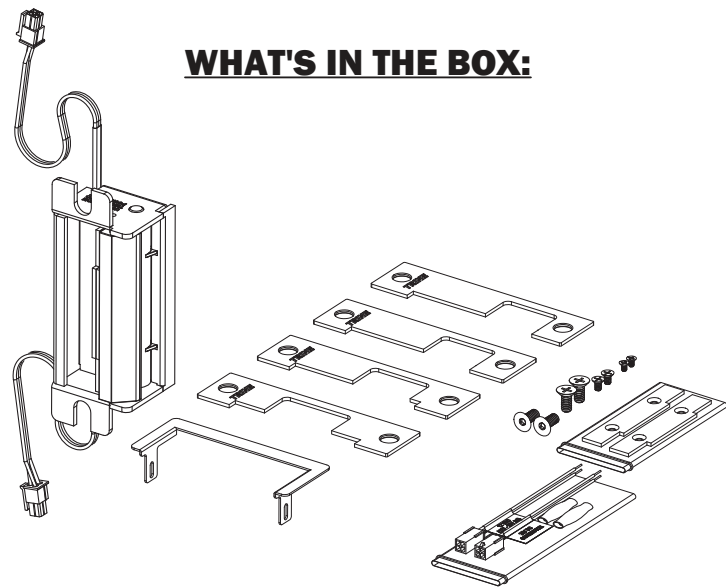

WHAT'S IN THE BOX:

- 1 - (1) 4100 Electric Strike Mechanism
- 2 - (4) Faceplates with Openings (CC, MHO, MMO, MLO)
- 3 - (2) #12-40 x 1 inch Philips Mounting Screws
- 4 - (2) #12-40 x 1 inch Torx® Security Mounting Screws
- 5 - (2) Quick Connect Socket and Wire Assembly 12VDC & 24VDC Version
- 6 - (2) Sealed Crimp Connectors
- 7 - (2) Latch Spacer Shims & (2) Mounting Screws
- 8 - (1) Frame Trim Skirt & (2) Screws

COMPATIBLE LOCKSETS:

CC: Centered Cylindrical (Reference HES® J faceplate)
Cylindrical Locksets up to 3/4" throw and all locksets center lined bolts: Corbin Russwin® Security Bolt, Weiserbolt®.

MHO: Mortise High Offset (Reference HES® KM faceplate)
Accurate®, Arrow®, Best®, Corbin Russwin®, Falcon® (1992M Series), Sargent® (7800, 8200 & 9200 Series), Yale® (8800).

MMO: Mortise Medium Offset (Reference HES® K faceplate)
Baldwin®, Marks®, PDQ®.

MLO: Mortise Low Offset (Reference HES® KD faceplate)
Jackson®, Sargent® (7700 & 8100), Schlage® (L Series), Yale® (8700).

4100 OPTIONS:

- 4100RS - FAIL SAFE CONFIGURATION
- 4100LB - LATCH BOLT MONITORING (1st quarter, 2013)
- 4100RSLB - FAIL SAFE/LATCH BOLT MONITORING (1st quarter, 2013)
- BZ-12 - 12VDC Piezo Buzzer
- BZ-24 - 24VDC Piezo Buzzer

Additional Faceplates:

- CCRD - 4-7/8" Centered Cavity with Radiused Corners
- CRD7 - 6-7/8" Tall Centered Cavity with Radiused Corners
- CRD8 - 7-15/16" Tall Centered Cavity with Radiused Corners
- CRD9 - 9" Tall Centered Cavity

FRAME PREPARATION

CC, MHO, MMO ON HOLLOW METAL FRAME

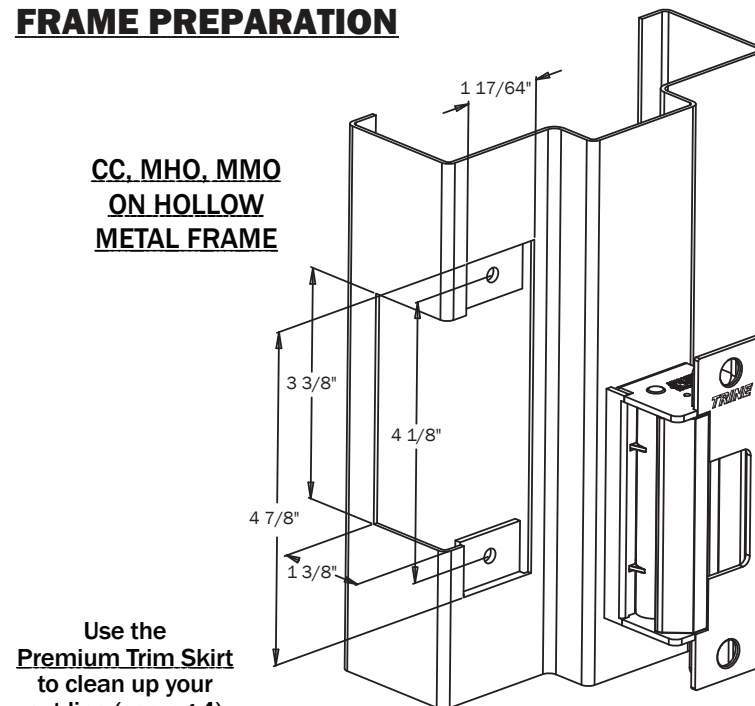

Use the **Premium Trim Skirt** to clean up your cut line (see pg 4)

MLO ON HOLLOW METAL FRAME (note 7/8" top dimension)

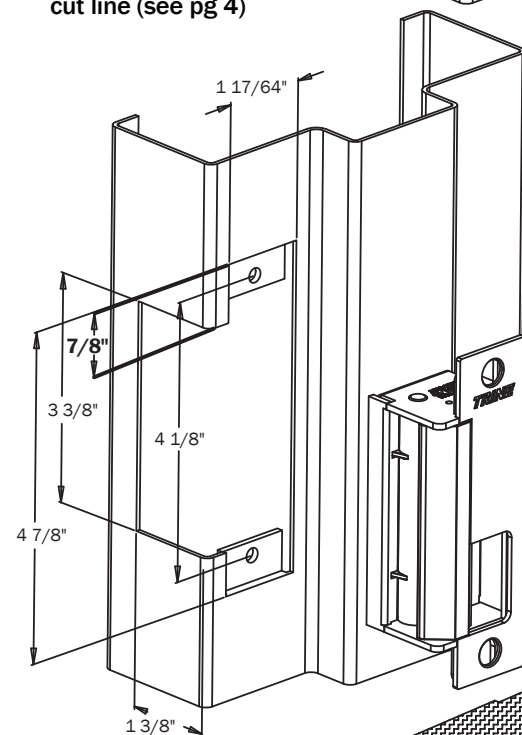

Use the **Premium Trim Skirt** to clean up your cut line (see pg 4)

ON WOOD FRAME

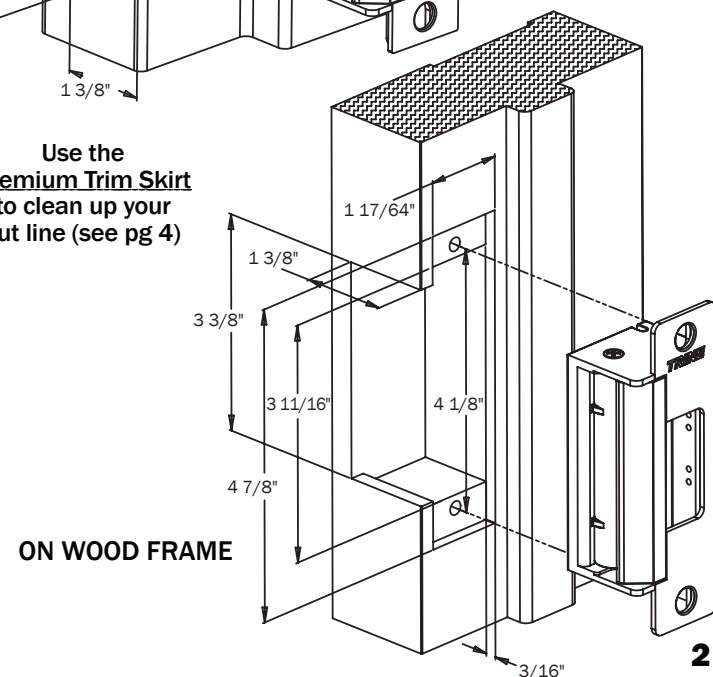

RECOMMENDED PRE-INSTALLATION CHECK:

1. Determine that the door swings without interfering with jamb or sill; the door must operate properly in order for the system to provide best results.
2. The door must be equipped with a door closer and the door closer "latch mode" must hold door in a completely closed position in order to avoid the lock latch from applying pressure against the releasing latch portion of the electric strike.
3. Electrical wire connections must be completed and ready to be terminated inside the frame.
4. Confirm that the power line in the frame is the correct voltage and that the switch works properly.
5. Confirm proper clearance exists between the end of the lock latch and jamb.
6. The faceplate opening used on the electric door strike must be centered with lock latch centerline when it is installed on the doorjamb.
7. For best installation results, the door frame must be reasonably flat and straight.

INSTALLING THE 4100 STRIKE:

NOTE: The 4100 electric strike has two terminal wires to supply power to two separate solenoids.
USE THE BOTTOM WIRE LEADS ONLY.

1. Prepare door frame as shown on page 2 (based on frame type).
2. Pull the switched power wires to the door frame. (Caution: Connect the power ONLY as the last step.)
3. Carefully choose the quick connect socket to match the required voltage. The quick connect sockets are labeled 12VDC (Blue Wire) or 24VDC (White Wire).
4. Use the crimp connectors to terminate the ends of the quick connect socket to the power wires coming out of the frame.

5. Connect the strikes bottom terminal to the quick connect socket.
6. Tuck the wires inside the door frame.
7. Install the electric strike into the door frame
8. Connect the power supply and turn power on.
9. Test your system.

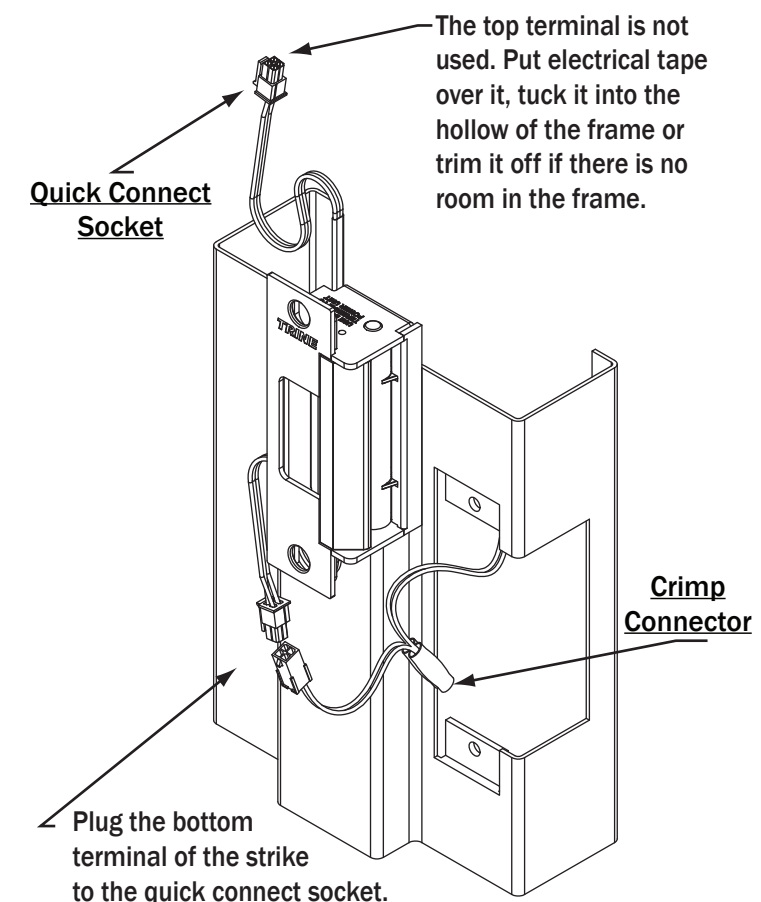

FACEPLATE AND OFFSET DIMENSIONS:

